

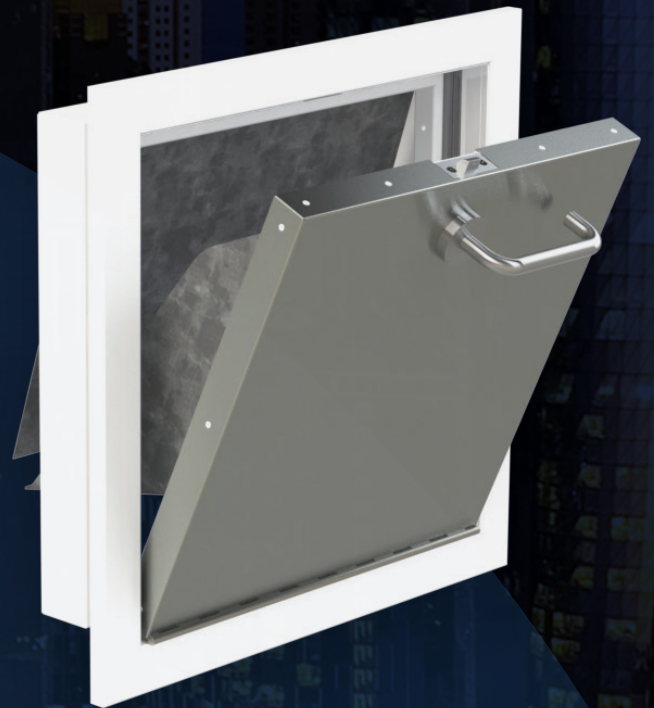

ELEPHANTS
FOOT

Chute Solutions

INTAKE DOORS



We Design, Manufacture & Install

EST. 1976

Intake Door

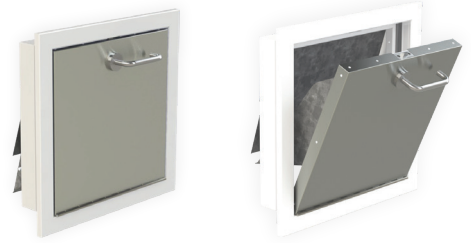

Elephants Foot offers a range of advanced chute intake doors, including Waste Doors, Dual Chute Doors, eDiverter® Doors, Linen Doors, and Custom Designs, all engineered to meet the highest fire compliance standards.

Ensure maximum safety with our fire-rated, self-closing chute intake doors, purpose-built for modern waste chute systems.

Fire-rated

Our intake chute doors are fire-rated and fully compliant with AS1530.4-2014 and NCC 2022 (C3.13/C4D14) regulations, ensuring superior safety and protection. Achieving a Fire Resistance Level (FRL) of -/120/30, they exceed NCC performance requirements. Our innovative intake doors deliver durable solutions for waste streams, redirection, and linen systems, making Elephants Foot the trusted choice for builders and developers.

SELF-CLOSING CHUTE INTAKE DOORS

Standard Door

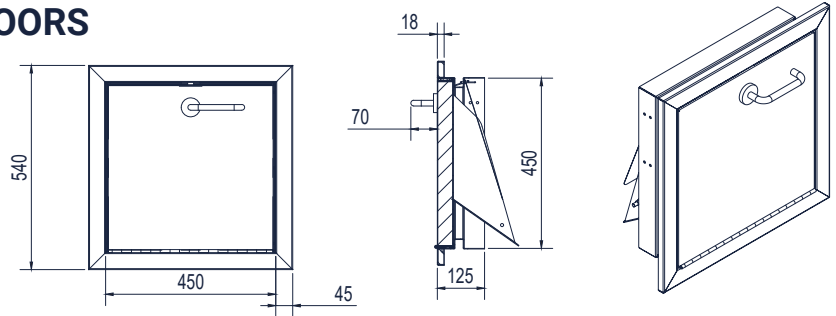

Linen Door

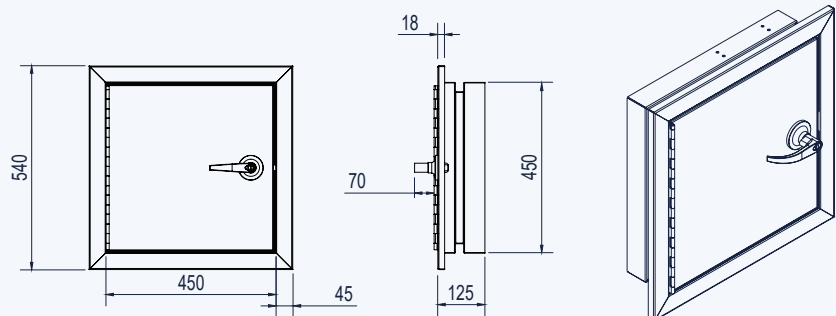

eDiverter® Door

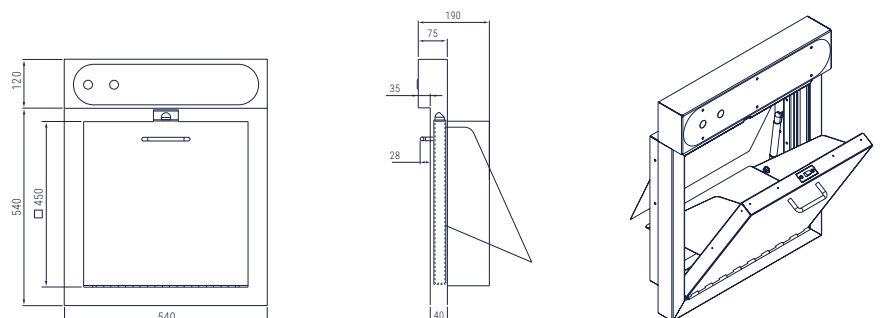

*To ensure the FRL is achieved, the shaft wall and aperture are to comply with code, standard and applicable manufactures specifications and tested system documentation, including approved Elephants Foot aperture details